



US009570713B2

(12) **United States Patent**
Park et al.

(10) **Patent No.:** **US 9,570,713 B2**
(45) **Date of Patent:** **Feb. 14, 2017**

(54) **ORGANIC LIGHT EMITTING DISPLAY DEVICE AND METHOD OF MANUFACTURING THE SAME**

(2013.01); **H01L 51/5293** (2013.01); **H01L 51/56** (2013.01); **H01L 27/3244** (2013.01)

(71) Applicant: **LG DISPLAY CO., LTD.**, Seoul (KR)

(58) **Field of Classification Search**
CPC H01L 51/5281; H01L 51/5284
See application file for complete search history.

(72) Inventors: **WonKi Park**, Paju-si (KR); **HyeJeong Park**, Jeonju-si (KR)

(56) **References Cited**

(73) Assignee: **LG DISPLAY CO., LTD.**, Seoul (KR)

U.S. PATENT DOCUMENTS

(*) Notice: Subject to any disclaimer, the term of this patent is extended or adjusted under 35 U.S.C. 154(b) by 0 days.

2008/0042553 A1 2/2008 Li
2010/0194268 A1* 8/2010 Choi H01L 27/3213
313/504
2012/0280259 A1 11/2012 Hatta H01L 27/3213
257/89
2013/0249383 A1 9/2013 Yoo et al.

(21) Appl. No.: **15/155,876**

FOREIGN PATENT DOCUMENTS

(22) Filed: **May 16, 2016**

(65) **Prior Publication Data**

US 2016/0260933 A1 Sep. 8, 2016

EP 0952478 A1 10/1999
KR 20090054756 A 6/2009
KR 101025863 B1 3/2011

Related U.S. Application Data

* cited by examiner

(63) Continuation of application No. 14/519,818, filed on Oct. 21, 2014, now Pat. No. 9,368,752.

Primary Examiner — Daniel Shook
(74) *Attorney, Agent, or Firm* — Dentons US LLP

(30) **Foreign Application Priority Data**

Nov. 11, 2013 (KR) 10-2013-0136465

(57) **ABSTRACT**

(51) **Int. Cl.**
H01L 51/52 (2006.01)
H01L 51/56 (2006.01)
H01L 27/32 (2006.01)

Disclosed is an organic light emitting display (OLED) device that may include first and second pixels on a substrate, each including a TFT region and a display region, the display region of each of the first and second pixels including a first electrode, an emission layer and a second electrode; a color filter layer in the display region of the second pixel; and a reflection preventing layer in the first and second pixels, substantially excluding the display region of the second pixel.

(52) **U.S. Cl.**
CPC **H01L 51/5281** (2013.01); **H01L 27/322** (2013.01); **H01L 27/3213** (2013.01); **H01L 27/3246** (2013.01); **H01L 27/3262** (2013.01); **H01L 51/5237** (2013.01); **H01L 51/5262**

20 Claims, 10 Drawing Sheets

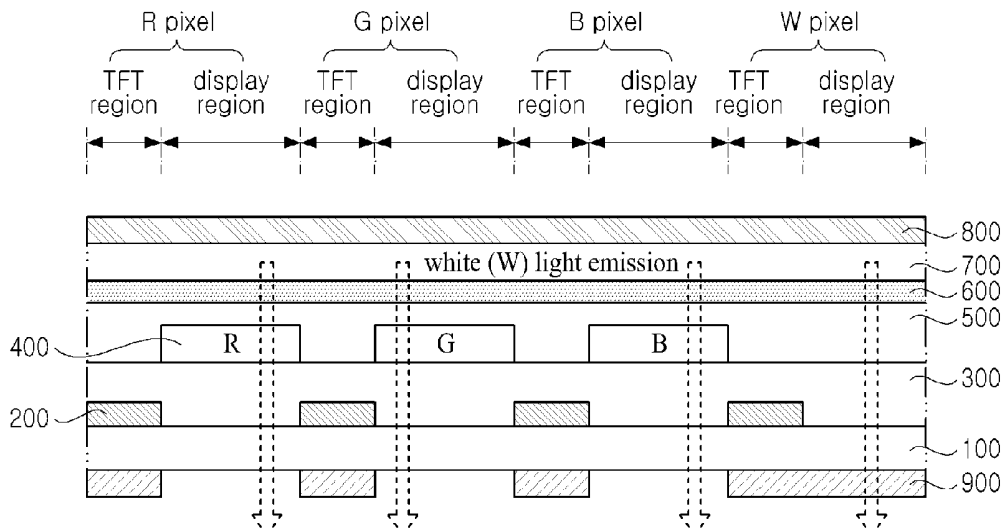

FIG. 1
(RELATED ART)

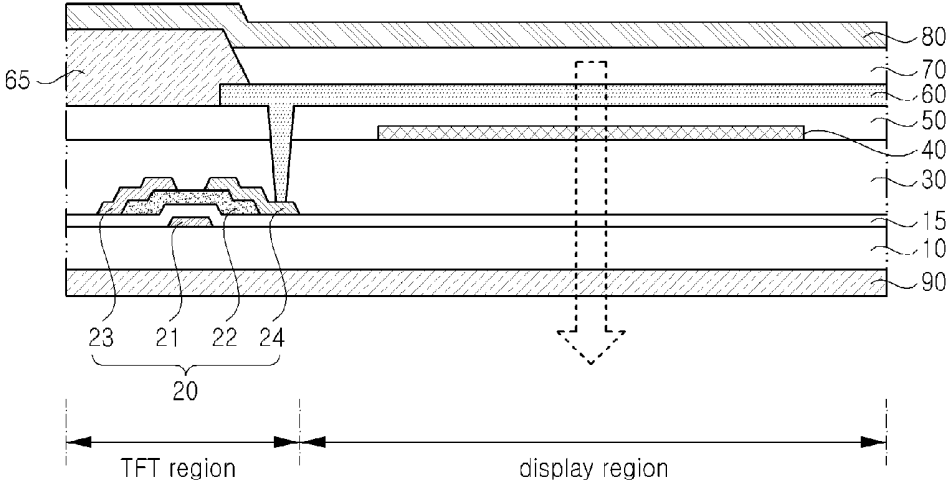

FIG. 2A

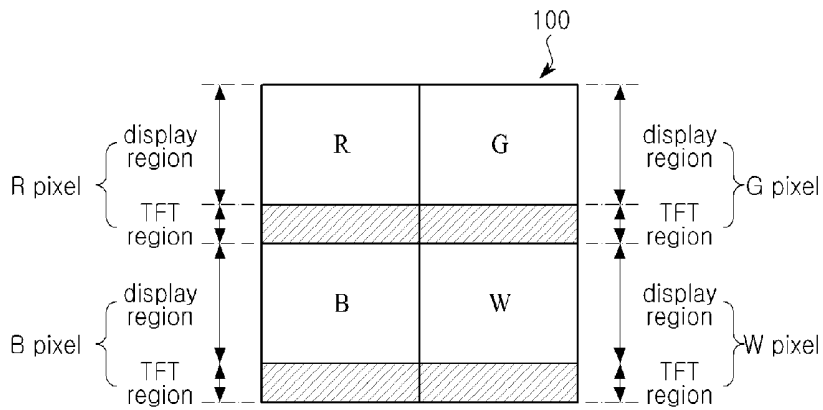

FIG. 2B

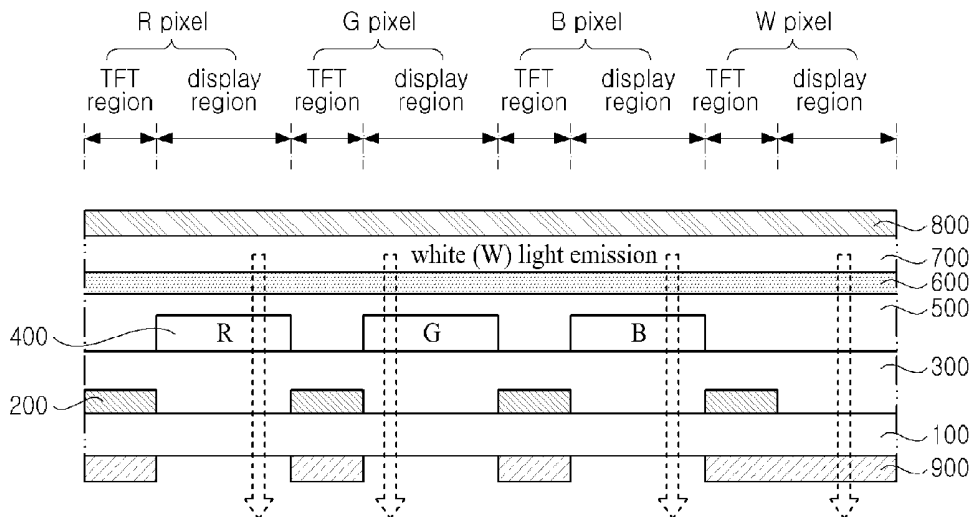

FIG. 3

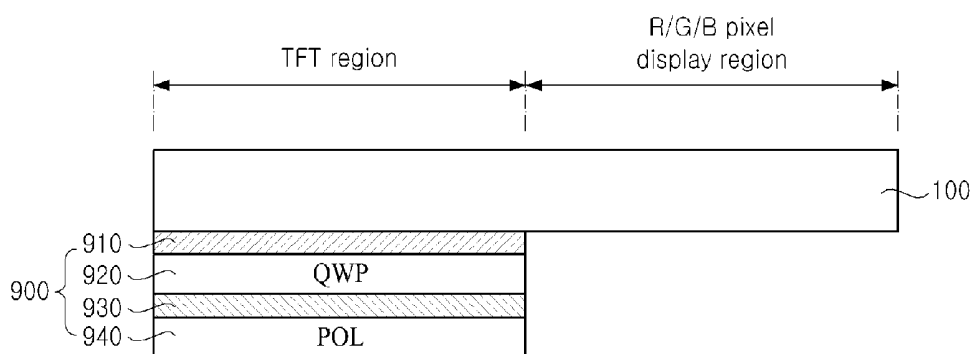

FIG. 4

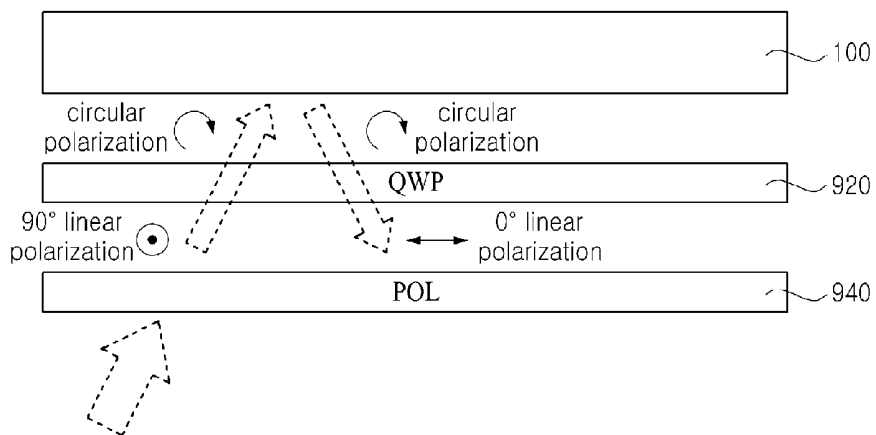

FIG. 5A

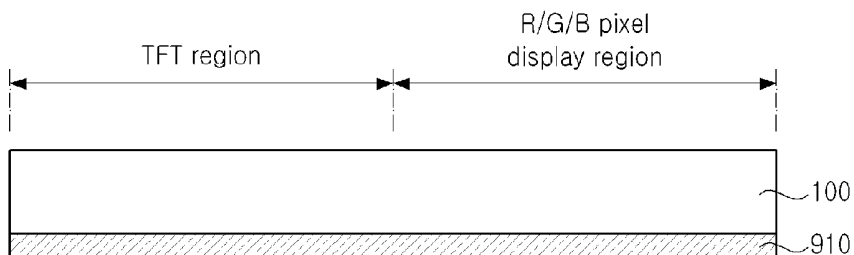

FIG. 5B

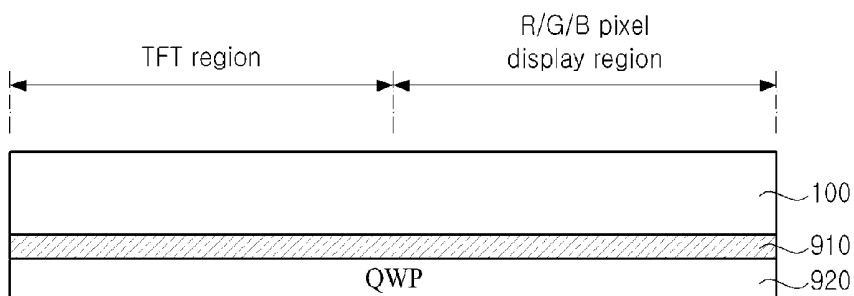

FIG. 5C

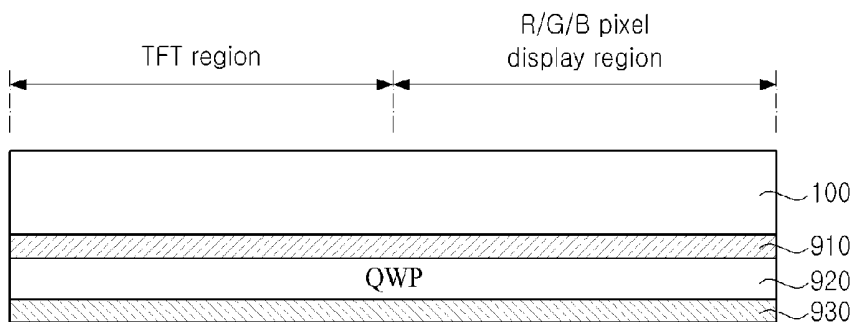

FIG. 5D

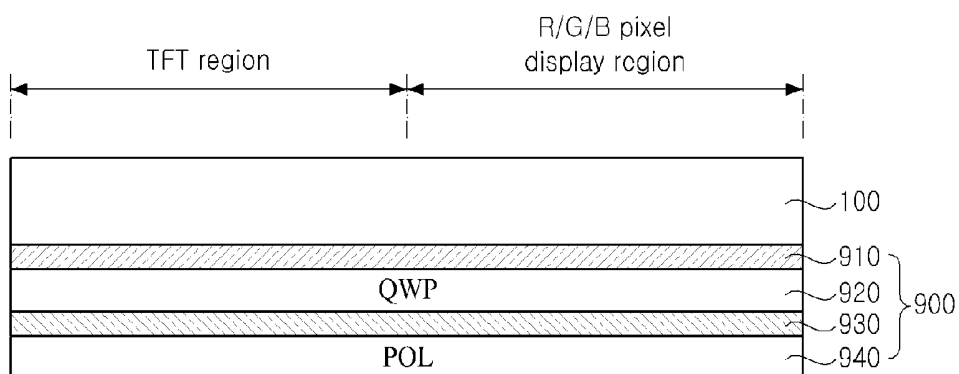

FIG. 5E

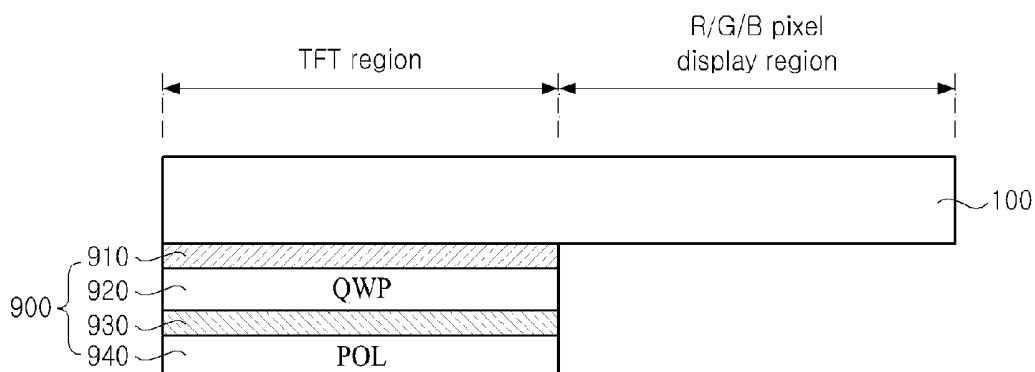

FIG. 6A

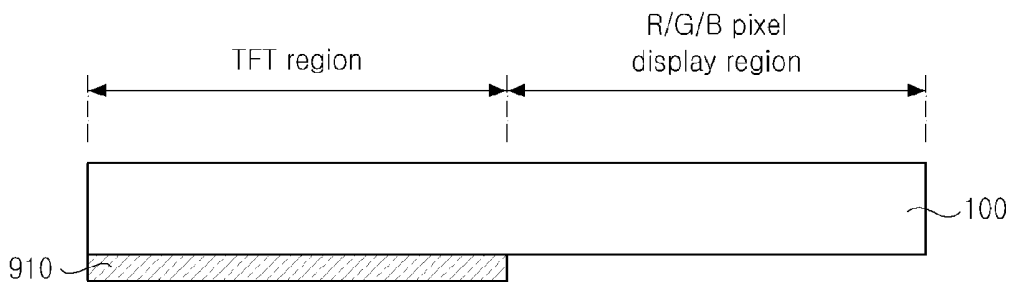

FIG. 6B

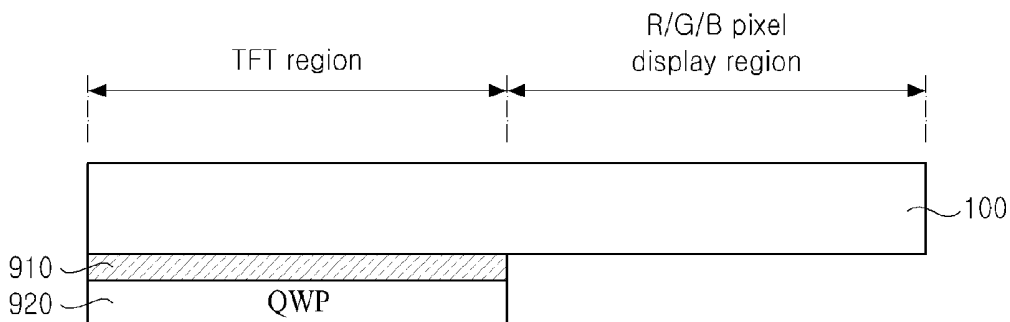

FIG. 6C

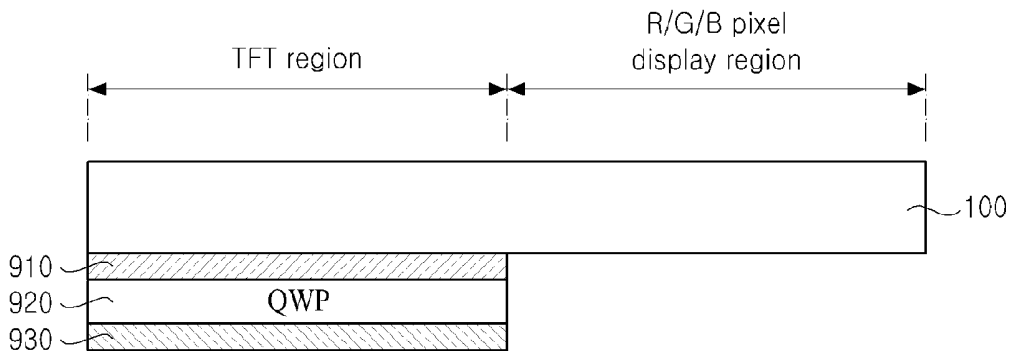

FIG. 6D

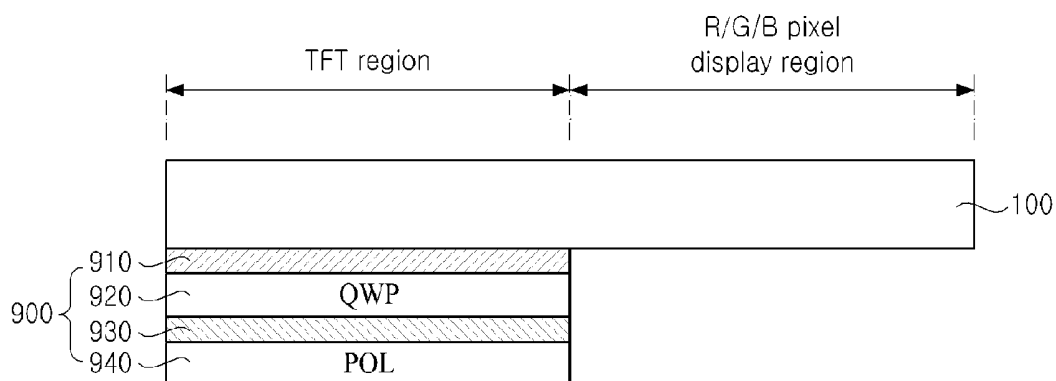

FIG. 7

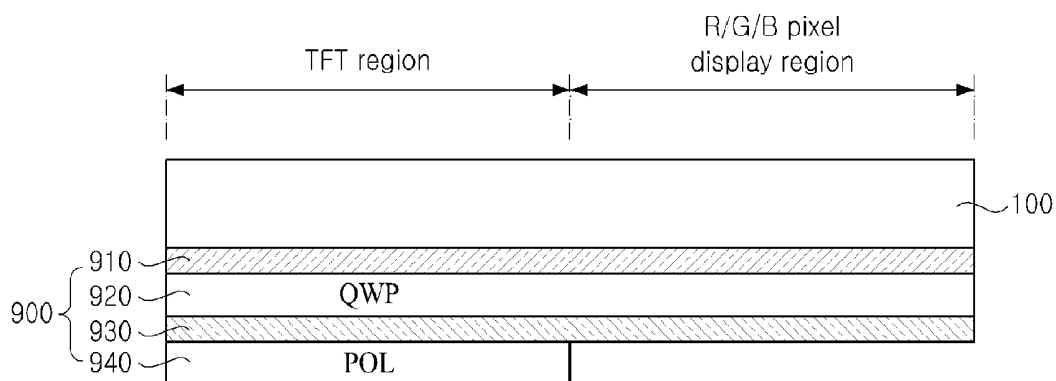

FIG. 8

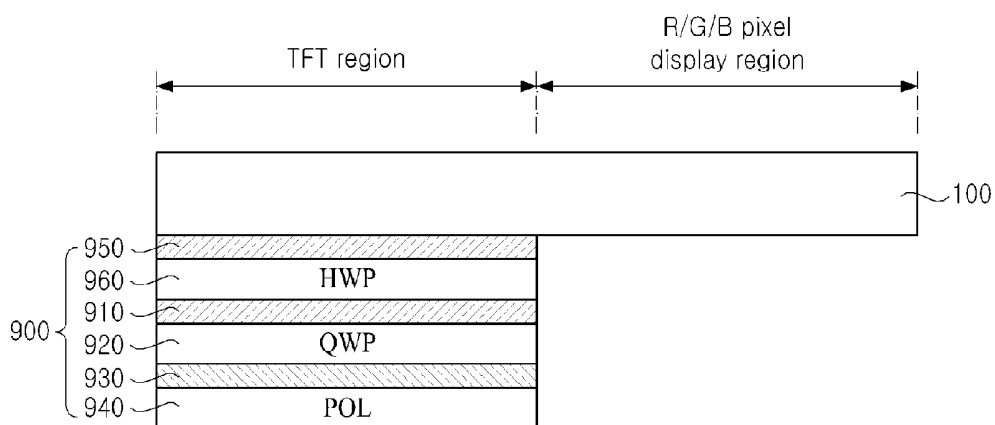

FIG. 9

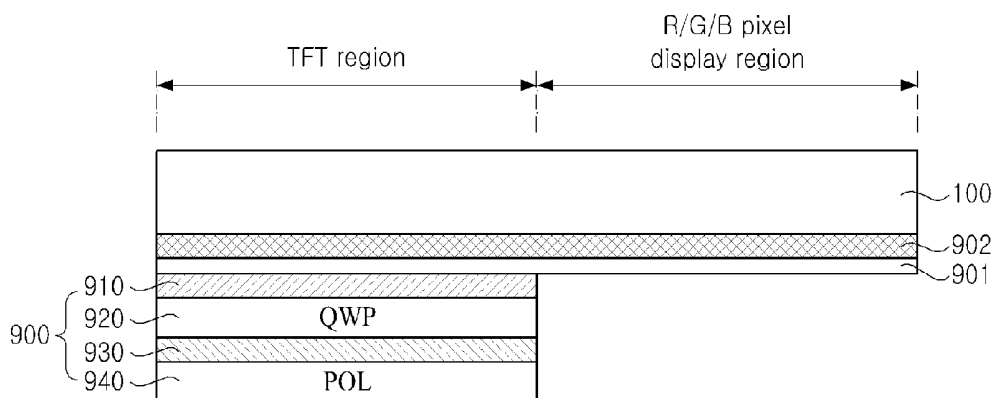

FIG. 10A

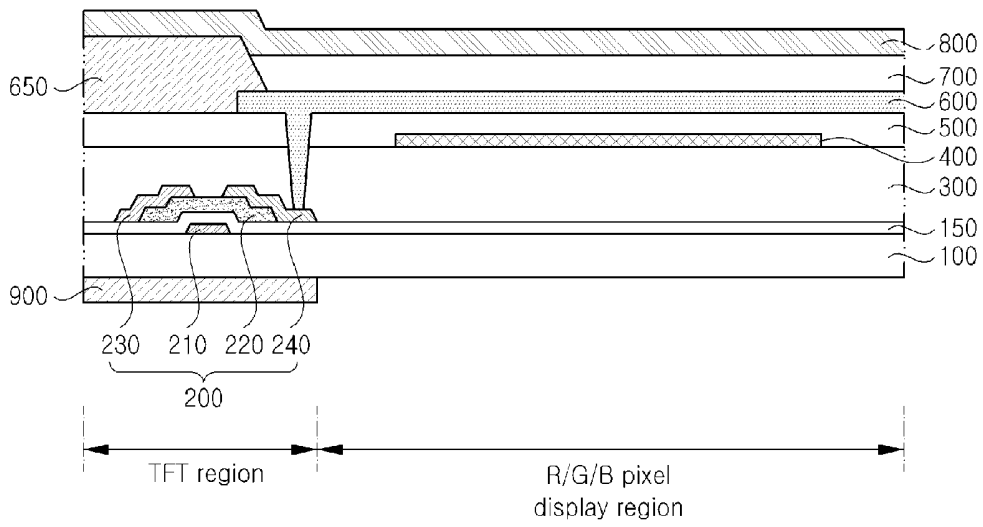

FIG. 10B

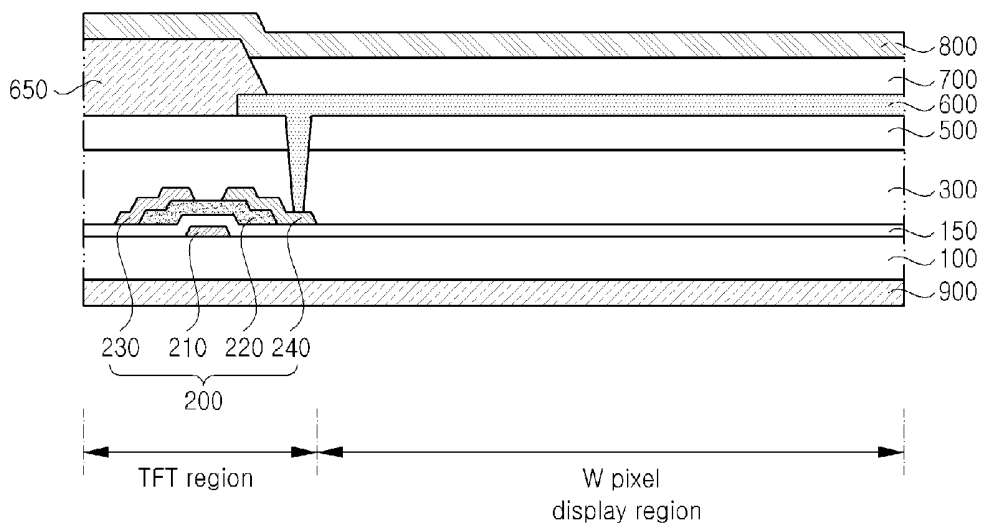
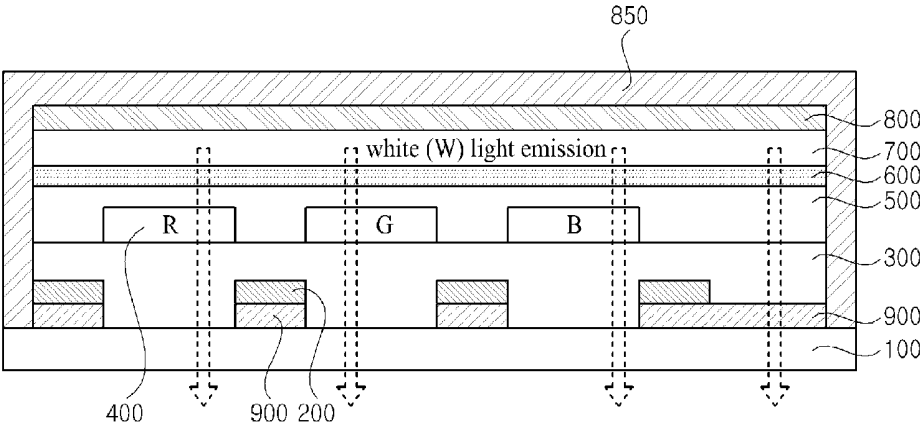

FIG. 11



**ORGANIC LIGHT EMITTING DISPLAY
DEVICE AND METHOD OF
MANUFACTURING THE SAME**

CROSS REFERENCE TO RELATED
APPLICATIONS

This application is a Continuation of U.S. patent application Ser. No. 14/519,818 filed on Oct. 21, 2014, which claims benefit of and priority to Korean Patent Application No. 10-2013-0136465 filed on Nov. 11, 2013, all of which are incorporated by reference for all purposes as if fully set forth herein.

BACKGROUND OF THE INVENTION

Field of the Invention

The present invention relate to an organic light emitting display (OLED) device and method of manufacturing the same, and more particularly, to an OLED device provided with a reflection preventing layer and method of manufacturing the same.

Discussion of the Related Art

An organic light emitting display (OLED) device includes a light emitting layer provided between a cathode for injecting electrons and an anode for injecting holes. When the electrons generated in the cathode and the holes generated in the anode are injected into the inside of the light emitting layer, excitons are produced by the recombination of the electrons and the holes. Then, when the excitons fall to a lower energy state from an excited state, the OLED device emits light.

Hereinafter, an OLED device according to the related art will be described with reference to the accompanying drawings.

FIG. 1 is a cross-sectional view illustrating the OLED device according to the related art.

As shown in FIG. 1, the OLED device according to the related art may include a substrate 10, a thin film transistor 20, a passivation film 30, a color filter layer 40, a planarization layer 50, a first electrode 60, a bank layer 65, a light emitting layer 70, a second electrode 80, and a reflection preventing layer 90.

The thin film transistor 20 is provided on an upper surface of the substrate 10. The thin film transistor 20 may include a gate electrode 21 patterned on the substrate 10, a semiconductor layer 22 insulated from the gate electrode 21 by a gate insulating film 15 interposed therebetween, and source and drain electrodes 23 and 24 provided at a fixed interval from each other and provided on the semiconductor layer 22.

The passivation film 30 is provided on the thin film transistor 20.

The color filter layer 40 is patterned on the passivation film 30.

The planarization layer 50 is provided on the color filter layer 40. A contact hole is formed in a predetermined region of the passivation film 30 and the planarization layer 50, whereby a drain electrode 24 of the thin film transistor 20 is exposed via the contact hole.

The first electrode 60 is patterned on the planarization layer 50. The first electrode 60 is connected with the drain electrode 24 via the contact hole.

The bank layer 65 is provided on the planarization layer 50. The bank layer 65 is provided on a thin film transistor (TFT) region, to thereby define a display region.

The light emitting layer 70 is provided on the first electrode 60, and is patterned on the display region defined by the bank layer 65. The light emitted from the light emitting layer 70 passes through the color filter layer 40 and then the substrate 10, to thereby display an image.

The second electrode 80 is provided on the light emitting layer 70.

The reflection preventing layer 90 is provided on a lower surface of the substrate 10, to thereby prevent external light from being reflected on the lower surface of the substrate 10. As described above, the thin film transistor 20 is formed in the TFT region. Thus, the external light is reflected due to a plurality of signal lines for forming the thin film transistor 20. In this respect, the reflection preventing layer 90 is provided on the lower surface of the substrate 10 so as to reduce or prevent the reflection of the external light.

However, in the OLED device according the related art, the reflection preventing layer 90, which is typically provided in a film type, is formed in both the TFT region and the display region, which lowers the light transmittance of the display region and the luminance of the OLED device. That is, when the light emitted from the light emitting layer 70 of the display region passes through the substrate 10 and then the reflection preventing layer 90, a considerable amount of light is absorbed in the reflection preventing layer 90, thereby causing a light loss.

SUMMARY OF THE INVENTION

Accordingly, the present invention is directed to an organic light emitting display (OLED) device and method of manufacturing the same that substantially obviates one or more problems due to limitations and disadvantages of the related art.

An advantage of the present invention is to provide an OLED device that is adapted to improve luminance by reducing or preventing a reflection of an external light.

Additional features and advantages of the invention will be set forth in the description which follows, and in part will be apparent from the description, or may be learned by practice of the invention. These and other advantages of the invention will be realized and attained by the structure particularly pointed out in the written description and claims hereof as well as the appended drawings.

To achieve these and other advantages and in accordance with the purpose of embodiments of the invention, as embodied and broadly described herein, an organic light emitting display (OLED) device may, for example, include first and second pixels on a substrate, each including a TFT region and a display region, the display region of each of the first and second pixels including a first electrode, an emission layer and a second electrode; a color filter layer in the display region of the second pixel; and a reflection preventing layer in the first and second pixels, substantially excluding the display region of the second pixel.

In another aspect of embodiments of the present invention, a method of manufacturing an organic light emitting display (OLED) device including first and second pixels on a substrate, each including a TFT region and a display region, the display region of each of the first and second pixels including a first electrode, an emission layer and a second electrode, the method comprising: forming a color filter layer in the display region of the second pixel; and forming a reflection preventing layer in the first and second pixels, substantially excluding the display region of the second pixel.

It is to be understood that both the foregoing general description and the following detailed description are exemplary and explanatory and are intended to provide further explanation of the invention as claimed.

BRIEF DESCRIPTION OF THE DRAWINGS

The accompanying drawings, which are included to provide a further understanding of embodiments of the invention and are incorporated in and constitute a part of this application, illustrate embodiment(s) of the invention and together with the description serve to explain the principle of embodiments of the invention. In the drawings:

FIG. 1 is a cross-sectional view illustrating an organic light emitting display (OLED) device according to the related art;

FIG. 2A and FIG. 2B are plan and cross-sectional views illustrating an OLED device according to an embodiment of the present invention, respectively;

FIG. 3 is a cross-sectional view illustrating a reflection preventing layer according to an embodiment of the present invention;

FIG. 4 is a concept view illustrating a function of a reflection preventing layer according to an embodiment of the present invention;

FIGS. 5A to 5E are views illustrating a manufacturing process for forming a reflection preventing layer according to an embodiment of the present invention;

FIGS. 6A to 6D are views illustrating a manufacturing process for forming a reflection preventing layer according to an embodiment of the present invention;

FIG. 7 illustrates an OLED device according to an embodiment of the present invention;

FIG. 8 is a cross-sectional view illustrating a reflection preventing layer according to an embodiment of the present invention;

FIG. 9 illustrates an OLED device according to an embodiment of the present invention;

FIGS. 10A and 10B are cross-sectional views illustrating an OLED device according to an embodiment of the present invention; and

FIG. 11 is a cross-sectional view illustrating an OLED device according to an embodiment of the present invention.

DETAILED DESCRIPTION OF THE ILLUSTRATED EMBODIMENTS

Reference will now be made in detail to embodiments of the present invention, examples of which are illustrated in the accompanying drawings. Wherever possible, the same reference numbers may be used throughout the drawings to refer to the same or like parts.

In the following description, when a first element is positioned "on" or "above" a second structure, the first and second elements may be in contact with each other, or a third element(s) may be interposed between the first and second elements. Also, when terms such as "the first" or "the second" are used to refer to elements, they may be used to separate any one element from other elements, but not necessarily define the order of corresponding elements.

Hereinafter, an organic light emitting display (OLED) device according to embodiments of the present invention and method of manufacturing the same will be described in detail with reference to the accompanying drawings.

FIG. 2A and FIG. 2B are plan and cross-sectional views illustrating an OLED device according to an embodiment of the present invention, respectively.

As illustrated in FIG. 2A, the OLED device may include red (R), green (G), blue (B) and white (W) pixels on a substrate **100**. The arrangement of the red (R), green (G), blue (B) and white (W) pixels may vary, and it is not, for example, limited to the above four pixels.

Each of the red (R), green (G), blue (B) and white (W) pixels may include a thin film transistor (TFT) region and a display region. A plurality of thin film transistors (TFT) and capacitors are formed in the TFT region, and a light emitting layer is formed in the display region. Thus, an image is displayed in the display region.

As illustrated in FIG. 2B, an OLED device may include a substrate **100**, a thin film transistor **200**, a passivation film **300**, a color filter layer **400**, a planarization layer **500**, a first electrode **600**, a light emitting layer **700**, a second electrode **800**, and a reflection preventing layer **900**.

The thin film transistor **200** is provided on an upper surface of the substrate **100**. In detail, the thin film transistor **200** is patterned in the TFT region for each of the red (R), green (G), blue (B) and white (W) pixels.

The passivation film **300** is provided on an entire area of the substrate **100** including the thin film transistor **200**.

The color filter layer **400** is patterned in the display region for each of the red (R), green (G), and blue (B) pixels. That is, the red (R) color filter layer **400** is formed in the display region of the red (R) pixel, the green (G) color filter layer **400** is formed in the display region of the green (G) pixel, and the blue (B) color filter layer **400** is formed in the display region of the blue (B) pixel.

The color filter layer **400** may not be formed in the display region of the white (W) pixel. In case of the white (W) pixel, a white-colored light, which is emitted from the light emitting layer **700**, is emitted intactly through the white (W) pixel. Thus, there may be no need for an additional color filter layer in the white (W) pixel. Meanwhile, in case of the red (R), green (G) and blue (B) pixels, when a white-colored light, which is emitted from the light emitting layer **700**, passes through each color filter layer **400**, the white-colored light is changed to light with a color of the corresponding pixel.

The planarization layer **500** is provided on an entire area of the substrate **100** including the color filter layer **400**.

The first electrode **600** is patterned on the planarization layer **500**. The first electrode **600** is formed of a transparent conductive material such as Indium-Tin-Oxide (ITO).

The light emitting layer **700** is patterned on the first electrode **600**. The light emitting layer **700** emits a white-colored light. Thus, the light emitting layer **700** may be formed by a combination of red, green and blue light emitting layers, or may be formed by a combination of orange and blue light emitting layers. The light emitting layer **700** may be formed in various types generally known to those skilled in the art.

The second electrode **800** is provided on the light emitting layer **700**.

The reflection preventing layer **900** is provided on a lower surface of the substrate **100**. The reflection preventing layer **900** is provided on the lower surface of the substrate **100** in a predetermined pattern.

In detail, the reflection preventing layer **900** is formed in the TFT region for each of the red (R), green (G), blue (B) and white (W) pixels. As the thin film transistor **200** is formed in the TFT region for each pixel on the upper surface of the substrate **100**, an external light is reflected due to a plurality of signal lines for forming the thin film transistor **200**. In order to reduce or prevent the external light from being reflected from the TFT region, the reflection prevent-

ing layer **900** is formed in the TFT region for each pixel. The reflection preventing layer **900** may be formed to cover an entire TFT region for each pixel.

Meanwhile, the reflection of an external light also occurs by the first electrode **600** in the display region for each of the red (R), green (G), blue (B) and white (W) pixels. In case of the red (R), green (G) and blue (B) pixels, the color filter layer **400** is formed between the first electrode **600** and the substrate **100**, whereby a considerable amount of the external light is absorbed in the color filter layer **400**. Thus, a problem caused by the reflection of external light scarcely occurs in the display region for each of the red (R), green (G) and blue (B) pixels, whereby the reflection preventing layer **900** may not be needed in the display region for each of the red (R), green (G) and blue (B) pixels.

However, since the color filter layer **400** is not formed in the white (W) pixel, a problem caused by the reflection of external light may occur therein. For this reason, the reflection preventing layer **900** is beneficially formed in the display region of the white (W) pixel.

Thus, the reflection preventing layer **900** is not formed in the display region for the pixels that have the color filter layer **400** between the first electrode **600** and the substrate **100** (e.g., red (R), green (G) and blue (B) pixels), and the reflection preventing layer **900** is formed in the display region for the pixel in which the color filter layer **400** is not formed between the first electrode **600** and the substrate **100** (e.g., white (W) pixel), whereby luminance is improved by reducing or minimizing the reflection of the external light and decreasing a loss of emitted light. That is, the reflection preventing layer **900** is not formed in the display region for each of the red (R), green (G) and blue (B) pixels so that it is possible to decrease the loss of light emitted therein, thereby improving the luminance.

In other words, the reflection preventing layer **900** is formed in the TFT region for each of the red (R), green (G), blue (B) and white (W) pixels, and the reflection preventing layer **900** is not formed in the display region for each of the red (R), green (G) and blue (B) pixels, whereby it is possible to reduce or prevent the reflection of an external light and to reduce or minimize the loss of light, thereby improving the luminance.

The reflection preventing layer **900** is not formed in an entire area of the lower surface of the substrate **100**, but is patterned in the predetermined portion. That is, it is difficult to apply a film-type reflection preventing layer as in the related art. Accordingly, the reflection preventing layer **900** according to an embodiment of the present invention is obtained by coating and patterning a coatable material layer, which will now be described in detail.

FIG. 3 is a cross-sectional view illustrating a reflection preventing layer according to one embodiment of the present invention. FIG. 4 is a concept view illustrating a function of a reflection preventing layer according to an embodiment of the present invention.

As illustrated in FIG. 3, the reflection preventing layer **900** according to an embodiment of the present invention may include a first alignment layer **910**, a quarter wave plate (QWP) **920**, a second alignment layer **930**, and a linear polarization layer (POL) **940**.

The first alignment layer **910** is provided on a lower surface of the substrate **100**, and the quarter wave plate **920** is provided on a lower surface of the first alignment layer **910**.

Since the first alignment layer **910** is aligned in a first direction, the first alignment layer **910** aligns a material for the quarter wave plate **920**, whereby the quarter wave plate

920 has a predetermined polarizing function. A manufacturing process thereof will now be described.

The first alignment layer **910** may be formed of a photo-alignment material such as acrylate-based material or epoxy-based material, but not limited to these materials.

The quarter wave plate **920** may be formed of reactive mesogen, and the quarter wave plate **920** may have a 45° or -45° transmission axis. The quarter wave plate **920** may serve to convert a 90° linear polarization into a circular polarization and a circular polarization into a 0° linear polarization.

The second alignment layer **930** is provided on a lower surface of the quarter wave plate **920**, and the linear polarization layer **940** is provided on a lower surface of the second alignment layer **930**.

Since the second alignment layer **930** is aligned in a second direction which is different from the first direction, the second alignment layer **930** aligns a material for the linear polarization layer **940**, whereby the linear polarization layer **940** has a predetermined polarizing function. A manufacturing process thereof will now be described.

The second alignment layer **930** may be formed of a photo-alignment material such as acrylate-based material or epoxy-based material, but not limited to these materials.

The linear polarization layer **940** may be formed of a mixture of reactive mesogen and dichromatic dye, or may be formed of a mixture of lyotropic liquid crystal and dichromatic dye. The linear polarization layer **940** may have a 90° transmission axis. The linear polarization layer **940** linearly polarizes the incident light at about 90° following the transmission axis.

As described above, the reflection preventing layer **900** according to an embodiment of the present invention may reduce or prevent the external light from being reflected by the use of quarter wave plate **920** and the linear polarization layer **940**, which will be described in detail with reference to FIG. 4.

As illustrated in FIG. 4, the quarter wave plate **920** is formed under the substrate **100**, and the linear polarization layer **940** is formed under the quarter wave plate **920**. As described above, the linear polarization layer **940** linearly polarizes the incident light at about 90° . Also, the quarter wave plate **920** converts a 90° linear polarization into a circular polarization and a circular polarization into a 0° linear polarization.

Accordingly, the external light is linearly polarized at 90° when the external light passes through the linear polarization layer **940**, and the linearly polarized light is then circularly polarized when it passes through the quarter wave plate **920**. Then, the circularly polarized light is reflected on the plurality of signal lines of the TFT region and the electrodes of the display region after it passes through the substrate **100**, and then the reflected light is linearly polarized at 0° while it passes through the quarter wave plate **920**. As the 0° linear polarization is substantially orthogonal to the transmission axis of the linear polarization layer **940**, it does not pass through the linear polarization layer **940**, to thereby reduce or prevent the reflection of the external light.

FIGS. 5A to 5E are views illustrating a manufacturing process for forming a reflection preventing layer according to an embodiment of the present invention, which relates to the manufacturing process of the reflection preventing layer illustrated in FIG. 3.

First, as illustrated in FIG. 5A, the first alignment layer **910** is formed on the lower surface of the substrate **100**.

The first alignment layer **910** is obtained by forming a photo-alignment material layer through a coating process of

a photo-alignment material such as acrylate-based material or epoxy-based material, drying a solvent in a drying oven, curing the photo-alignment material layer, and aligning the photo-alignment material layer in the first direction by a rubbing or polarized UV irradiation.

Then, as illustrated in FIG. 5B, the quarter wave plate 920 is formed on the lower surface of the first alignment layer 910.

The quarter wave plate 920 is obtained by coating the lower surface of the first alignment layer 910 with reactive mesogen, drying a solvent in the drying oven, and curing the coated material. This curing process may be performed by a UV irradiation.

The first alignment layer 910 is aligned in the first direction. Thus, the quarter wave plate 920 is aligned by the first alignment layer 910 during the drying process in the drying oven, whereby the quarter wave plate 920 may have a 45° or -45° transmission axis.

After that, as illustrated in FIG. 5C, the second alignment layer 930 is formed on the lower surface of the quarter wave plate 920.

The second alignment layer 930 is obtained by forming a photo-alignment material layer through a coating process of a photo-alignment material such as acrylate-based material or epoxy-based material, drying a solvent in the drying oven, curing the photo-alignment material layer, and aligning the photo-alignment material layer in the second direction by a rubbing or polarized UV irradiation.

As illustrated in FIG. 5D, the linear polarization layer 940 is formed on the lower surface of the second alignment layer 930.

The linear polarization layer 940 is obtained by coating the mixture of reactive mesogen and dichromatic dye or the mixture of lyotropic liquid crystal and dichromatic dye onto the lower surface of the second alignment layer 930, drying a solvent in the drying oven, and curing the coated material. This curing process may be performed by a UV irradiation.

The second alignment layer 930 is aligned in the second direction. Thus, the linear polarization layer 940 is aligned by the second alignment layer 930 during the drying process in the drying oven, whereby the linear polarization layer 940 may have a 45° or -45° transmission axis.

As illustrated in FIG. 5E, the reflection preventing layer 900 is patterned by removing the predetermined portions from the first alignment layer 910, the quarter wave plate 920, the second alignment layer 930 and the linear polarization layer 940.

The process of removing the predetermined portions from the first alignment layer 910, the quarter wave plate 920, the second alignment layer 930 and the linear polarization layer 940 may be performed by a photolithography process of photo resist coating, exposure, development, etching and stripping.

As described above, the predetermined portions of the first alignment layer 910, the quarter wave plate 920, the second alignment layer 930 and the linear polarization layer 940, which are to be removed, correspond to the display regions for the red (R), green (G) and blue (B) pixels.

FIGS. 6A to 6D are views illustrating a manufacturing process for forming the reflection preventing layer according to another embodiment of the present invention, which relates to the manufacturing process of the reflection preventing layer illustrated in FIG. 3.

First, as illustrated in FIG. 6A, the first alignment layer 910 is patterned on the lower surface of the substrate 100. The first alignment layer 910 is not formed in the display region for each of the red (R), green (G) and blue (B) pixels,

but formed in the TFT region for each pixel and the display region for the white (W) pixel.

The first alignment layer 910 is obtained by forming a photo-alignment material layer through a coating process of a photo-alignment material such as acrylate-based material or epoxy-based material, drying a solvent in the drying oven, curing the photo-alignment material layer, aligning the photo-alignment material layer for the TFT region for each pixel and the display region for the white (W) pixel in the first direction by irradiating a polarized UV light onto the TFT region for each pixel and the display region for the white (W) pixel, and removing the photo-alignment material layer from the display region for each of the red (R), green (G) and blue (B) pixels that is not irradiated with the polarized UV light.

Then, as illustrated in FIG. 6B, the quarter wave plate 920 is formed on the lower surface of the first alignment layer 910. The quarter wave plate 920 is not formed in the display region for each of the red (R), green (G) and blue (B) pixels, but formed in the TFT region for each pixel and the display region for the white (W) pixel.

The quarter wave plate 920 is obtained by coating the lower surface of the first alignment layer 910 with reactive mesogen, curing the reactive mesogen in the TFT region for each pixel and the display region for the white (W) pixel by irradiating a polarized UV light onto the TFT region for each pixel and the display region for the white (W) pixel, and removing the reactive mesogen from the display region for each of the red (R), green (G) and blue (B) pixels that is not irradiated with the polarized UV.

After that, as illustrated in FIG. 6C, the second alignment layer 930 is formed on the lower surface of the quarter wave plate 920. The second alignment layer 930 is not formed in the display region for each of the red (R), green (G) and blue (B) pixels, but formed in the TFT region for each pixel and the display region for the white (W) pixel.

The second alignment layer 930 is obtained by forming a photo-alignment material layer through a coating process of a photo-alignment material such as acrylate-based material or epoxy-based material, drying a solvent in the drying oven, curing the photo-alignment material layer, aligning the photo-alignment material layer for the TFT region for each pixel and the display region for the white (W) pixel in the second direction by irradiating a polarized UV light onto the TFT region for each pixel and the display region for the white (W) pixel, and removing the photo-alignment material layer from the display region for each of the red (R), green (G) and blue (B) pixels that is not irradiated with the polarized UV.

As illustrated in FIG. 6D, the linear polarization layer 940 is formed on the lower surface of the second alignment layer 930, to thereby complete the pattern for the reflection preventing layer 900. The linear polarization layer 940 is not formed in the display region for each of the red (R), green (G) and blue (B) pixels, but formed in the TFT region for each pixel and the display region for the white (W) pixel.

The linear polarization layer 940 is obtained by coating the mixture of reactive mesogen and dichromatic dye or the mixture of lyotropic liquid crystal and dichromatic dye onto the lower surface of the second alignment layer 930, curing the mixture in the TFT region for each pixel and the display region for the white (W) pixel by irradiating a polarized UV light onto the TFT region for each pixel and the display region for the white (W) pixel, and removing the mixture from the display region for each of the red (R), green (G) and blue (B) pixels that is not irradiated with the polarized UV.

Referring back to FIG. 2B, the OLED device according to one embodiment of the present invention may be manufactured by forming the thin film transistor **200** on one surface of the substrate **100**, that is, the upper surface of the substrate **100**; forming the passivation film **300** on the thin film transistor **200**; forming the color filter layer **400** on the passivation film **300**; forming the planarization layer **500** on the color filter layer **400**; forming the first electrode **600** on the planarization layer **500**; forming the light emitting layer **700** on the first electrode **600**; forming the second electrode **800** on the light emitting layer **700**; and forming the reflection preventing layer **900** on the other surface of the substrate **100**, that is, the lower surface of the substrate **100** in accordance with the method illustrated in FIGS. 5A to 5E or the method illustrated in FIGS. 6A to 6D. These elements may be formed by various methods generally known to those skilled in the art.

FIG. 7 illustrates an OLED device according to another embodiment of the present invention. The OLED device of FIG. 7 is obtained by additionally forming at least one material layer for the aforementioned reflection preventing layer **900** of FIG. 3 in the display region for each of the red (R), green (G) and blue (B) pixels.

In FIG. 3, the material layer for forming the reflection preventing layer **900** is not formed in the display region for each of the red (R), green (G) and blue (B) pixels. In case of FIG. 7, a first alignment layer **910**, a quarter wave plate **920** and a second alignment layer **930** constituting the reflection preventing layer **900**, except a linear polarization layer **940**, are formed in the display region for each of the red (R), green (G) and blue (B) pixels.

The linear polarization layer **940** transmits only a linearly polarized light having a specific transmission axis among various transmission axes. Thus, if the incident light passes through the linear polarization layer **940**, it might cause a considerable loss of the light. Meanwhile, the first alignment layer **910**, the quarter wave plate **920** and the second alignment layer **930** correspond to a phase retarder. Thus, even though the light passes through the above first alignment layer **910**, the quarter wave plate **920** and the second alignment layer **930**, there may be no or small light loss. Accordingly, as illustrated in FIG. 7, even though the first alignment layer **910**, the quarter wave plate **920** and the second alignment layer **930** are formed in the display region for each of the red (R), green (G) and blue (B) pixels, there may be no or small light loss.

In FIG. 7, all the first alignment layer **910**, the quarter wave plate **920** and the second alignment layer **930** are formed in the display region for each of the red (R), green (G) and blue (B) pixels, but not limited to this structure. That is, at least any one layer of the first alignment layer **910**, the quarter wave plate **920** and the second alignment layer **930** may be formed in the display region for each of the red (R), green (G) and blue (B) pixels. For example, only the first alignment layer **910** may be formed in the display region for each of the red (R), green (G) and blue (B) pixels, and alternatively, only the first alignment layer **910** and quarter wave plate **920** may be formed in the display region for each of the red (R), green (G) and blue (B) pixels.

FIG. 8 is a cross-sectional view illustrating a reflection preventing layer according to another embodiment of the present invention.

As illustrated in FIG. 8, the reflection preventing layer **900** according to another embodiment of the present invention is obtained by additionally forming a third alignment layer **950** and a half wave plate (HWP) **960** between a lower surface of a substrate **100** and a first alignment layer **910**.

That is, the reflection preventing layer **900** of FIG. 8 may include the third alignment layer **950**, the half wave plate **960**, a first alignment layer **910**, a quarter wave plate (QWP) **920**, a second alignment layer **930** and a linear polarization layer (POL) **940**, which are sequentially provided on the lower surface of the substrate **100**.

In FIG. 3, the reflection preventing layer **900** uses the quarter wave plate **920** as a phase retarder. Meanwhile, the reflection preventing layer **900** of FIG. 8 uses a combination of the half wave plate **960** and the quarter wave plate **920** as a phase retarder.

The third alignment layer **950** is provided on the lower surface of the substrate **100**, and the third alignment layer **950** is aligned in a third direction which may be different from the aforementioned first and second directions. The third alignment layer **950** aligns a material for the half wave plate **960**, whereby the half wave plate **960** has a predetermined polarizing function.

The third alignment layer **950** may be formed of a photo-alignment material such as acrylate-based material or epoxy-based material, but not limited to these materials.

The half wave plate **960** may be formed of reactive mesogen, and the half wave plate **960** may have a 15° transmission axis. In this case, the quarter wave plate **920** may have a 75° transmission axis.

A manufacturing process for the third alignment layer **950** and the half wave plate **960** may be similar to the aforementioned manufacturing process for the first alignment layer **910** and the quarter wave plate **920** illustrated in FIGS. 5A to 5C. That is, the third alignment layer **950** may be obtained by forming a photo-alignment material layer through a coating process of a photo-alignment material such as acrylate-based material or epoxy-based material on the lower surface of the substrate **100**, drying a solvent in the drying oven, curing the photo-alignment material layer, and aligning the photo-alignment material layer in the third direction by a rubbing or polarized UV irradiation. The half wave plate **960** may be obtained by coating the lower surface of the third alignment layer **950** with reactive mesogen, drying a solvent in the drying oven, and curing the coated material. In this case, since the third alignment layer **950** is aligned in the third direction, the half wave plate **960** is aligned by the third alignment layer **950** during the drying process in the drying oven, whereby the half wave plate **960** may have a 15° transmission axis.

Although not shown in the drawings, it is possible to additionally form at least any one layer of the third alignment layer **950**, the half wave plate **960**, the first alignment layer **910**, the quarter wave plate **920** and the second alignment layer **930** in the display region for each of the red (R), green (G) and blue (B) pixels.

FIG. 9 illustrates an OLED device according to another embodiment of the present invention. In case of FIG. 9, instead of directly forming a reflection preventing layer on a lower surface of a substrate **100**, the reflection preventing layer **900** is provided on an additional film **901**, and then the film **901** is adhered to the lower surface of the substrate **100** by the use of an adhesive **902**.

In the same manner as in FIG. 3, the reflection preventing layer **900** of FIG. 9 may include a first alignment layer **910**, a quarter wave plate **920**, a second alignment layer **930** and a linear polarization layer **940**. However, it is also possible to apply the structure of FIG. 7 or FIG. 8 to the reflection preventing layer **900** of FIG. 9.

The film **901** may be formed of PET-based (polyethylene terephthalate) material, acrylic-based material or TAC-based (Tri-Acetyl Cellulose) material, but not limited to these materials.

The adhesive **902** may be formed of various materials generally known to those skilled in the art, for example, urethane-based material.

FIGS. **10A** and **10B** are cross-sectional views illustrating an OLED device according to another embodiment of the present invention, wherein FIG. **10A** illustrates red (R), green (G) and blue (B) pixels, and FIG. **10B** illustrates a white (W) pixel.

As illustrated in FIG. **10A**, the red (R), green (G) or blue (B) pixel is constructed with a substrate **100**, a thin film transistor **200**, a passivation film **300**, a color filter layer **400**, a planarization layer **500**, a first electrode **600**, a bank layer **650**, a light emitting layer **700**, a second electrode **800** and a reflection preventing layer **900**.

The substrate **100** is a base substrate, wherein the substrate **100** may be formed of glass or transparent plastic. If needed, the substrate **100** may be formed of a flexible material.

The thin film transistor **200** is provided on an upper surface of the substrate **100**, especially, a TFT region. The thin film transistor **200** may include a gate electrode **210** patterned on the substrate **100**, a semiconductor layer **220** insulated from the gate electrode **210** by a gate insulating film **150** interposed therebetween, and source and drain electrodes **230** and **240** provided at a fixed interval from each other and provided on the semiconductor layer **220**. As illustrated in the drawings, the thin film transistor **200** is formed in a bottom gate structure in which the gate electrode **210** is positioned below the semiconductor layer **220**. The thin film transistor **200** may be formed in a top gate structure in which the gate electrode **210** is positioned above the semiconductor layer **220**. The thin film transistor **200** may be formed in various types generally known to those skilled in the art.

The passivation film **300** is provided on the thin film transistor **200**, wherein the passivation film **300** is formed in both the TFT region and the display region. The passivation film **300** may be formed of a single-layered insulating film, or may be formed of a dual-layered structure of inorganic insulating layer and organic insulating layer.

The color filter layer **400** is patterned on the passivation film **300**, especially, in the display region. The color filter layer **400** may include red (R), green (G) and blue (B) color filters respectively formed for the red (R), green (G) and blue (B) pixels.

The planarization layer **500** is provided on the color filter layer **400**. The planarization layer **400** is formed in both the TFT region and the display region, to thereby planarize the surface of substrate **100**. A contact hole is formed in a predetermined region of the passivation film **300** and planarization layer **500**, whereby a drain electrode **240** of the thin film transistor **200** is exposed via the contact hole.

The first electrode **600** is provided on the planarization layer **500**. The first electrode **600** is connected with the drain electrode **240** via the contact hole. The first electrode **600** may function as an anode.

The bank layer **650** is provided on the first electrode **600**. The bank layer **650** is provided on the TFT region, to thereby define the display region.

The light emitting layer **700** is provided on the first electrode **600**, and is patterned on the display region defined by the bank layer **650**. The light emitting layer **700** is formed to emit a white-colored light.

The second electrode **800** is provided on the light emitting layer **700**. The second electrode **800** may be formed to serve as a common electrode. Thus, the second electrode **800** may be provided on an entire area of the substrate **100** including the bank layer **650**. The second electrode **800** may function as a cathode.

Although not shown in the drawings, an encapsulation layer for preventing a moisture permeation from the external may be provided on the second electrode **800**, a sealing layer may be provided on the encapsulation layer, and a protection substrate may be provided on the sealing layer.

The reflection preventing layer **900** is provided on a lower surface of the substrate **100**. The reflection preventing layer **900** is not formed in the display region, but formed in the TFT region. A detailed structure of the reflection preventing layer **900** is the same as that of the reflection preventing layer described above, whereby a detailed description for the structure of the reflection preventing layer **900** will be omitted.

As illustrated in FIG. **10B**, the white (W) pixel is constructed with the substrate **100**, the thin film transistor **200**, the passivation film **300**, the planarization layer **500**, the first electrode **600**, the bank layer **650**, the light emitting layer **700**, the second electrode **800** and the reflection preventing layer **900**.

Unlike the aforementioned red (R), green (G) and blue (B) pixels, the white (W) pixel is not provided with the color filter layer **400**. Also, since the color filter layer **400** is not formed in the white (W) pixel, the reflection preventing layer **900** is formed not only in the TFT region for the white (W) pixel but also in the display region for the white (W) pixel to reduce or prevent the reflection of an external light in the display region for the white (W) pixel.

FIG. **11** is a cross-sectional view illustrating an OLED device according to another embodiment of the present invention. As illustrated in FIG. **11**, a reflection preventing layer **900** is not provided on a lower surface of a substrate **100**, but provided on an upper surface of the substrate **100**.

As illustrated in FIG. **11**, the OLED may include the substrate **100**, the reflection preventing layer **900**, a thin film transistor **200**, a passivation film **300**, a color filter layer **400**, a planarization layer **500**, a first electrode **600**, a light emitting layer **700**, a second electrode **800** and a sealing layer **850**.

The reflection preventing layer **900** is provided on the upper surface of the substrate **100**. In the same manner as those described above, the reflection preventing layer **900** is not formed in the display region for each of the red (R), green (G) and blue (B) pixels, but formed in the TFT region for each pixel and the display region for the white (W) pixel.

The thin film transistor **200** is provided on the reflection preventing layer **900**. The passivation film **300**, the color filter layer **400**, the planarization layer **500**, the first electrode **600**, the light emitting layer **700** and the second electrode **800** may have a similar or identical structure to those described above, whereby a detailed description will be omitted.

The sealing layer **850** is provided on the second electrode **800**, to thereby seal the OLED device. In this case, the sealing layer **850** is provided to seal an entire lateral surface of the reflection preventing layer **900** so as to reduce or prevent the reflection preventing layer **900** from being exposed to the external. If the lateral surface of the reflection preventing layer **900** is exposed to the external, an external moisture might permeate through the exposed lateral surface of the reflection preventing layer **900**. For this reason, the entire lateral surface of the reflection preventing layer **900** is

sealed by the sealing layer **850**, to thereby reduce or prevent permeation of an external moisture. To this end, the reflection preventing layer **900** is not provided on an entire upper surface of the substrate **100**. That is, the reflection preventing layer **900** is not formed in an edge of the substrate **100**. Accordingly, the sealing layer **850** is formed in the edge of the substrate **100** without the reflection preventing layer **900**.

The above description of the OLED device relates to a bottom emission type device in which an image is displayed by the light emitted toward a lower direction of the substrate **100**, but not limited to this method. An OLED device according to the present invention may be applied to a top emission type device in which an image is displayed by the light emitted toward an upper direction of the substrate **100**.

According to an embodiment of the present invention, the reflection preventing layer **900** is not formed in the display region of the pixels that have the color filter layer, but formed in the display region of the pixel that does not have the color filter layer, whereby it is possible to improve the luminance by reducing or minimizing reflection of an external light and decreasing loss of light.

It will be apparent to those skilled in the art that various modifications and variation can be made in the present invention without departing from the spirit or scope of the invention. Thus, it is intended that the present invention cover the modifications and variations of this invention provided they come within the scope of the appended claims and their equivalents.

What is claimed is:

1. An organic light emitting display (OLED) device comprising:

first, second, third and fourth pixels on a first surface of a substrate, each of the first, second, third and fourth pixels including a display region and a non-display region;

a color filter layer in the first, second and third pixels, a first reflection preventing layer in the non-display region of each of the first, second and third pixels; and a second reflection preventing layer in the non-display region of the fourth pixel and the display region of the fourth pixel,

wherein the first and second reflection preventing layers are on a second surface facing the first surface of the substrate.

2. The OLED device according to claim 1, wherein one of the first, second and third pixels is any one of red, green and blue pixels, and the fourth pixel is a white pixel.

3. The OLED device according to claim 1, wherein the second reflection preventing layer in the non-display region of the fourth pixel has the substantially same thickness as that of the second reflection preventing layer in the display region of the fourth pixel.

4. The OLED device according to claim 1, wherein the first and second reflection preventing layers include a first alignment layer on the second surface of the substrate, a quarter wave plate on the first alignment layer, a second alignment layer on the quarter wave plate, and a linear polarization layer on the second alignment layer.

5. The OLED device according to claim 4, wherein the first and second reflection preventing layers further include a third alignment layer and a half wave plate between the substrate and the first alignment layer.

6. The OLED device according to claim 1, wherein the display region of each of the first, second and third pixels is provided with at least any one of an alignment layer, a half wave plate, a quarter wave plate.

7. The OLED device according to claim 1, further comprising a film on the substrate with an adhesive therebetween, and wherein the first and second reflection preventing layers is provided on the film.

8. The OLED device according to claim 1, wherein a lateral surface of the reflection preventing layer is sealed by a sealing layer.

9. The OLED device according to claim 1, wherein the display region of each of the first, second, third and fourth pixels includes a first electrode, an emission layer and a second electrode, and the emission layer emits a white light.

10. The OLED device according to claim 1, wherein the first and second reflection preventing layers include a phase retarder.

11. An organic light emitting display (OLED) device comprising:

first, second, third and fourth pixels on a substrate, each of the first, second, third and fourth pixels including a display region and a non-display region;

a color filter layer in the first, second and third pixels, a first reflection preventing layer in the non-display region of each of the first, second and third pixels; and a second reflection preventing layer in the non-display region of the fourth pixel and the display region of the fourth pixel,

wherein the second reflection preventing layer in the non-display region of the fourth pixel has the substantially same thickness as that of the second reflection preventing layer in the display region of the fourth pixel.

12. The OLED device according to claim 11, wherein the first and second reflection preventing layers include a first alignment layer on a first surface of the substrate, a quarter wave plate on the first alignment layer, a second alignment layer on the quarter wave plate, and a linear polarization layer on the second alignment layer.

13. The OLED device according to claim 12, wherein the first and second reflection preventing layers further include a third alignment layer and a half wave plate between the substrate and the first alignment layer.

14. The OLED device according to claim 11, wherein the display region of each of the first, second and third pixels is provided with at least any one of an alignment layer, a half wave plate, a quarter wave plate.

15. The OLED device according to claim 11, further comprising a film on the substrate with an adhesive therebetween, and wherein the first and second reflection preventing layers is provided on the film.

16. The OLED device according to claim 11, wherein a lateral surface of the reflection preventing layer is sealed by a sealing layer.

17. The OLED device according to claim 11, wherein the first and second reflection preventing layers include a phase retarder.

18. An organic light emitting display (OLED) device comprising:

first, second, third and fourth pixels on a substrate, each of the first, second, third and fourth pixels including a display region and a non-display region;

a color filter layer in the first, second and third pixels, a first reflection preventing layer in the non-display region of each of the first, second and third pixels; and a second reflection preventing layer in the non-display region of the fourth pixel and the display region of the fourth pixel,

wherein the first and the second reflection preventing layers include at least one layer that changes a polarization direction of an incident light.

19. The OLED device according to claim 18, wherein the at least one layer includes a first layer and a second layer, 5 and

wherein the first layer is configured to linearly polarize the light, and the second layer is configured to circularly polarize the linearly polarized light and linearly polarizes the circularly polarized light. 10

20. The OLED device according to claim 19, wherein a linear polarization of the linearly polarized light from the circularly polarized light is substantially orthogonal to a transmission axis of the first layer.

* * * * *

专利名称(译)	有机发光显示装置及其制造方法		
公开(公告)号	US9570713	公开(公告)日	2017-02-14
申请号	US15/155876	申请日	2016-05-16
[标]申请(专利权)人(译)	乐金显示有限公司		
申请(专利权)人(译)	LG DISPLAY CO. , LTD.		
当前申请(专利权)人(译)	LG DISPLAY CO. , LTD.		
[标]发明人	PARK WONKI PARK HYEJEONG		
发明人	PARK, WONKI PARK, HYEJEONG		
IPC分类号	H01L51/52 H01L51/56 H01L27/32		
CPC分类号	H01L51/56 H01L51/5281 H01L27/322 H01L27/3213 H01L27/3246 H01L27/3262 H01L51/5237 H01L51/5262 H01L51/5293 H01L27/3244		
代理机构(译)	DENTONS美国律师事务所		
审查员(译)	舒克, DANIEL		
优先权	1020130136465 2013-11-11 KR		
其他公开文献	US20160260933A1		
外部链接	Espacenet USPTO		

摘要(译)

公开了一种有机发光显示器 (OLED) 器件, 其可以包括在衬底上的第一和第二像素, 每个像素包括TFT区域和显示区域, 第一和第二像素中的每一个的显示区域包括第一电极, 发射层和第二电极; 在所述第二像素的显示区域中的滤色器层; 以及在第一和第二像素中的反射防止层, 基本上不包括第二像素的显示区域。

